

INSTALLATION AND OPERATING INSTRUCTIONS

LUX ELV4 Programmable Heating Thermostat

Single Pole and Double Pole Line Voltage

52005

WARNING: Use Energizer® or DURACELL® Alkaline Batteries Only.

Energizer® is a registered trademark of Eveready Battery Company, Inc.
DURACELL® is a registered trademark of The Gillette Company, Inc.

Mt. Laurel, New Jersey 08054, USA
http://www.luxproducts.com



Thank you for your confidence in our product. To obtain the best results from your investment, please read these instructions and acquaint yourself with your purchase.

COMPATIBILITY

This programmable thermostat is compatible with either Single Pole* (see wiring instructions) or Double Pole, 125/250 VAC, line voltage heating systems up to 16 Amps. The heating wattage rating is 1900 Watts (Non-Inductive) for 125 VAC, and 3800 Watts (Non-Inductive) for 250 VAC. This thermostat cannot be used with: cooling systems, conventional 24 Volt systems, hydronic hot water systems, or heat pump systems. Ask your dealer for other LUX thermostats to control those systems. NOTE: Disconnection Type: "TYPE 1B".

FEATURES

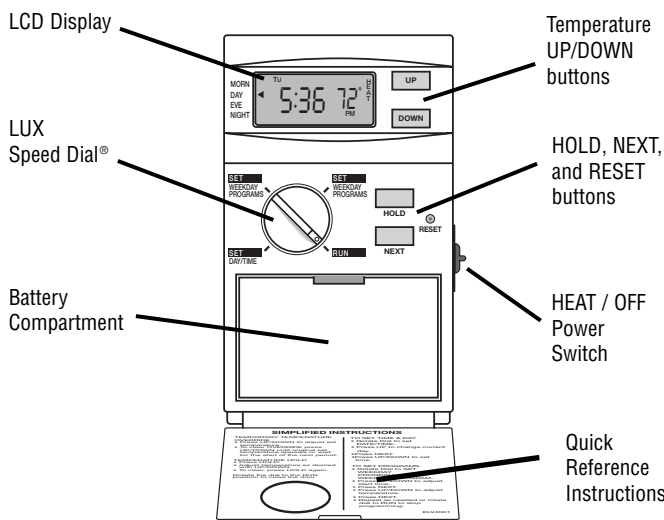

- Heating Only
- Armchair Programmable
- 3 Year Warranty
- On Screen Low Battery Indicator
- Default Energy Star® Approved Program
- Attractive Design
- Exclusive LUX Speed Dial®
- 5/2 Day Programming
- 4 Periods Per Day
- Battery Free Memory Storage

- Temporary Temperature Override
- Temperature Hold
- F/C Temperature Display
- 12/24 Hr Clock Display
- Adjustable Temperature Swing
- 5 or 2 Minute Selectable Minimum Run/Off Time

INSTALLATION

Please read ALL of these instructions carefully before beginning installation. Save them for future reference.

WARNING

- This Thermostat is a line voltage (125 / 250 VAC) control. Do not attempt to install it unless you are completely familiar with line-voltage wiring. If improperly handled, there is a risk of electric shock hazard which may cause serious injury or death.
- The thermostat is rated for normal full load current from a double 15A circuit breaker or fuse block. Do not use on circuits with current protection devices that are rated higher than 15 amps.
- Maximum load for this thermostat **MUST NOT** exceed 3800 Watts, otherwise a potential fire hazard exists.

MOUNTING LOCATION:

Install a vertical, electrical switch box for mounting the thermostat approximately 5 Feet (1.5 Meters) above the floor on an inside wall where the thermostat will be exposed to average room temperature. The use of a "deep" style switch box will make the installation easier by providing more room for making the wiring connections. The thermostat must be placed away from concealed warm or cold water pipes, air ducts, or drafts from hallways, direct sunlight, fireplaces, or stairways in order to sense room temperature properly. Do not place the thermostat directly above any of the heating elements.

CAUTION

Turn off electricity to your heating system prior to installing this thermostat, or servicing any part of the system. Do not turn electricity back on until installation is fully completed.

WIRING:

1. Disconnect power before removing your old thermostat (if applicable). Double check that this thermostat is rated for the voltage and amperage to be switched.
2. Remove the front portion of the thermostat by carefully pressing the button at the bottom of the thermostat and swinging the body up and away.
3. When replacing an old line voltage wall thermostat, remove it carefully to avoid damage to the insulation on the wiring. Check the old insulation for cracks, nicks, or fraying and apply certified electrical tape where necessary to achieve adequate insulation, or replace the wires in an approved fashion.
4. Use the diagrams shown in the "WIRE IDENTIFICATION AND WIRING SCHEMATICS" section of this manual to ensure that the thermostat connections are made to the proper wires for your installation.

NOTE:

All wiring performed must comply with applicable codes and ordinances to your local area.

5. Attach the wires together using the solder-less wire connectors (provided), and be sure that all wire connectors are tight and secure.
6. Bend the solid conductors, and then push them and the wire connectors into the electrical box carefully, providing enough clearance behind the mounting screw locations. Secure the thermostat base to the electrical box with the mounting screws.

NOTE:

When you are finished performing your installation and setup options, please remove the thin plastic film that is protecting the LCD display screen on the front of the thermostat. This plastic may or may not be present, and is evident by the appearance of fake digits appearing on the display screen.

7. Place the thermostat front portion onto the back plate by first catching the plastic tabs at the top, and then firmly pressing the bottom of the thermostat towards the back plate to latch the halves together.
8. Install two new Energizer® or DURACELL® "AA" size alkaline batteries before continuing further. Ensure that the batteries are installed in the proper direction as per the markings shown in the battery tray. The battery tray is located in the front of the thermostat, behind the door.
9. Now turn the supply power back on to the heating system.

NOTE:

This thermostat is protected against normal static electric discharges, however to minimize the risk of damaging the unit in extremely dry weather, touch a grounded metal object before touching your thermostat.

SETUP OPTIONS

The settings, options, and components listed in this section below are located on the rear of the thermostat, on the circuit board.

OPTION SWITCHES:

There is a square box with 2 small switches, located to the right side of the circuit board. Each switch controls a different setting depending on the position of the switch. The individual switches are labeled as 1 and 2, and there is a corresponding table printed on the circuit board to show the possible options for each of the two switch positions.

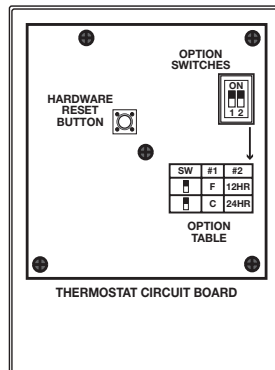

TEMPERATURE SCALE (Option Switch #1):

This determines how the thermostat displays all temperatures on the screen. Switch position OFF is F°, and ON is C°.

TIME FORMAT (Option Switch #2):

This determines how the thermostat displays the clock and all other times on the screen. Switch position OFF is 12 HR, and ON is 24 HR.

HARDWARE RESET:

The hardware reset is a push button that is located near the center of the circuit board. This reset button is used by the thermostat to read the position of the option switches. When either of the two option settings above are changed, the hardware reset button must be pushed for the change to be recognized. User temperature programs are not erased when a hardware reset is performed.

FRONT PANEL ITEMS

SOFTWARE RESET:

The Software Reset is a small recessed push button that is located to the right of the NEXT and HOLD buttons. This button can be pushed with a pencil or the end of a paper clip. The software reset clears all of the user temperature programs, and all other software preferences to their default values. You should write down your heating program times and temperatures prior to using the Software Reset.

PUSH BUTTONS:

There are four primary push buttons on the front of the thermostat: The UP and DOWN arrow keys, the NEXT button, and the HOLD button.

ROTARY DIAL:

The LUX Speed Dial® provides an easy way to quickly navigate between the different programming areas. This rotary dial has four individual positions.

HEAT / OFF SWITCH:

This switch is located on the right side of the power unit (back half of thermostat) as shown to the right. In the winter, set the power switch to HEAT to control your heating system. In the spring, summer, and fall, set the switch to OFF if you would like to prevent your heating system from turning on.

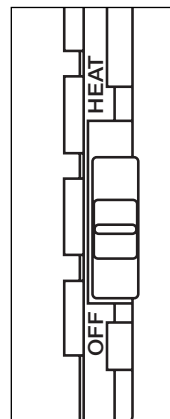

OPERATING INSTRUCTIONS

SET DAY/TIME:

Rotate the dial to the SET DAY/TIME position. The day of the week will start flashing on the display. With the day flashing, press the UP button, once for each day, to advance to the desired day of the week. Press the NEXT button; this should cause the time to start flashing and the day to remain on steady. Using either the UP or DOWN buttons, adjust the clock to the desired time. The clock digits will increment rapidly if either the UP or DOWN buttons are held in the pressed position.

TEMPERATURE OVERRIDE:

A Temperature Override occurs in Run mode, anytime the user adjusts the set temperature to a value other than what the stored program set temperature is for that day and time. When the thermostat is in an Override, the word "OVERRIDE" will appear in the bottom of the display screen. The thermostat will maintain thermal control using this new set temperature, until the start of the next program period time is reached. At that time, the set temperature will return to the value stored in memory for that new program period. To enter an Override, push either the UP or DOWN button once and the set temperature will begin to flash. Push either the UP or DOWN button to the desired set temperature value. An Override may be cancelled by rotating the dial or by initiating a HOLD.

TEMPERATURE HOLD:

A Temperature Hold is similar to an override, but is used for maintaining a constant set temperature under manual control, for a longer time duration. A Hold is the simplest means to set and maintain a fixed temperature. It allows you to set and maintain a fixed temperature indefinitely, without concern for programming.

A temperature Hold may be used for days, weeks, or even months at a time. To enter a Hold, push the HOLD button once, and the word "HOLD" will appear in the temperature portion of the screen, along with the flashing set temperature. While the set temperature is flashing, push either the UP or DOWN button to the new desired set temperature value. To cancel a Hold, press and release the HOLD button once again, or rotate the dial away from RUN.

POWER UNIT DISCONNECTED INDICATOR:

In the lower right of the display screen, there is an icon (shown) to confirm that the front (control) portion of the thermostat is separated from the back (power unit) portion of the thermostat.



ADVANCED FEATURES

SWING SETTING:

A thermostat works by turning your heating system on and off whenever the room temperature varies from the set-point temperature. The amount of this variation is called the "swing". Your system should cycle on about 3 to 6 times per hour. A smaller swing number increases the number of cycles per hour, so the room temperature is more precise and constant. A larger swing number decreases the number of cycles per hour, but saves energy in most cases. To change the Swing setting, turn the dial to RUN mode. Hold down the NEXT button and push the HOLD button once, then let go of both. A single number will appear on the screen. Use the UP/DOWN buttons to change the number value between 1 and 9. Number 1 is the default setting. Press the NEXT button to accept the setting and return to normal Run mode.

MINIMUM RUN TIME DELAY:

This is determined by the thermostat, and controls the minimum length of time that the thermostat must remain with the Heat either On or Off, before it will automatically switch to the alternate On or Off state. This feature prevents rapid undesired cycling of the heating equipment. The time amount for this delay is fixed at 5 minutes between on or off load changes.

PROGRAMMING

For the two program types that are described below, this thermostat provides four independent periods per day for Heat mode, they are: MORN, DAY, EVE, and NITE. Each period ends at the start time of the following period. When you install batteries for the first time, or perform a Software Reset, an Energy Star® approved temperature program (shown below) is inserted into all four of the program periods. You can use this default program, or alter any portion of it to suit your own preferences. When setting the program items, the value that is flashing is the item that you can change at that time.

| PERIOD | TIME / TEMPERATURE |
|--------|------------------------|
| MORN | 6:00 AM 70 °F (21 °C) |
| DAY | 8:00 AM 62 °F (17 °C) |
| EVE | 6:00 PM 70 °F (21 °C) |
| NITE | 10:00 PM 62 °F (17 °C) |

SET WEEKDAY PROGRAM:

Rotate the dial to WEEKDAY PROGRAM. You will be programming all five weekdays at the same time. The first period is MORN. Using the UP and DOWN buttons, set the start time for this period, and then push the NEXT button to proceed. Now set the desired set temperature for the MORN period using the UP and DOWN buttons, and push NEXT to proceed. Now set the start time and set temperature for the DAY period, pushing NEXT after each to advance. Continue with these same steps to set the start time and set temperature for the EVE, and NITE program periods. When you are finished setting all four periods, you may continue pushing the NEXT button through all four periods to review your entries, or turn the dial to RUN if you are finished.

SET WEEKEND PROGRAM:

Turn the dial to WEEKEND PROGRAM. You will be programming both Saturday and Sunday at the same time. You will begin with the start time of the MORN period, and use the same procedures that were performed while setting the Weekday Program periods, using the NEXT button to advance through the values. Return the dial to the RUN position when you are finished.

BATTERIES AND MAINTENANCE

The batteries should be replaced AT LEAST once per year, or sooner if the LOW BATT battery symbol appears in the lower left portion of the display screen as shown. To replace the batteries in the thermostat, open the front door of the unit. The battery compartment is located just below the rotary dial and push buttons. Pull the battery compartment out, starting with the top edge. Remove the used batteries from the battery tray and discard appropriately.

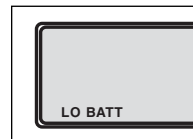

Install two new Energizer® or DURACELL®, "AA" size alkaline batteries into the battery tray. Observe the polarity markings shown in the battery compartment to ensure proper installation. When finished, re-install the battery compartment by first seating the bottom into its alignment pins, and pivoting the top in towards the thermostat to snap the latch back into place.

TECHNICAL ASSISTANCE

If you have any problems installing or using this thermostat, please carefully and thoroughly review the instruction manual. If you require assistance, please contact our Technical Assistance Department at 856-234-8803 during regular business hours between 8:00AM and 4:30PM Eastern Standard Time, Monday through Friday. You can also receive technical assistance online anytime day or night at http://www.luxproducts.com. Our web site offers you answers to the most common technical questions, and also permits you to email your questions to our technical support staff at your convenience.

WARRANTY

Limited Warranty: If this unit fails because of defects in materials or workmanship within three years of the date of original purchase, LUX will, at its option, repair or replace it. This warranty does not cover damage by accident, misuse, or failure to follow installation instructions. Implied warranties are limited in duration to three years from the date of original purchase. Some states do not allow limitations on how long an implied warranty lasts, so the above limitation may not apply to you. Please return malfunctioning or defective units to the location from which the purchase was made, along with proof of purchase. Please refer to "TECHNICAL ASSISTANCE" before returning thermostat. Purchaser assumes all risks and liability for incidental and consequential damage resulting from installation and use of this unit. Some states do not allow the exclusion of incidental or consequential damages, so the above exclusion may not apply to you. This warranty gives you specific legal rights and you may also have other rights which vary from state to state. Applicable in the U.S.A. and Canada only.

(ELV4) ENGLISH - WIRE IDENTIFICATION AND WIRING SCHEMATICS

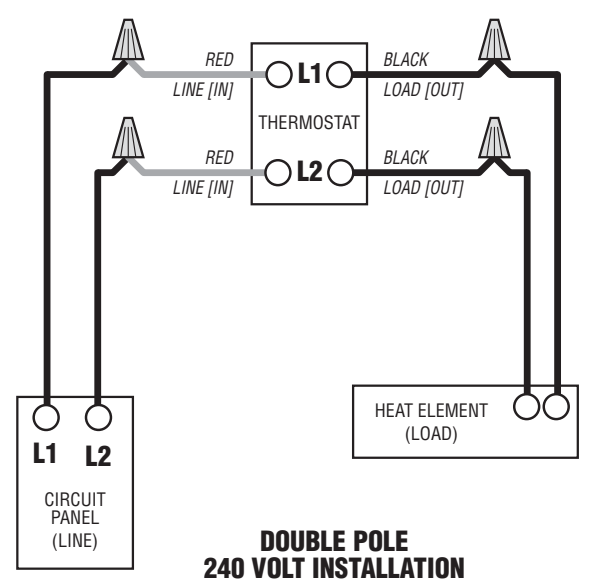
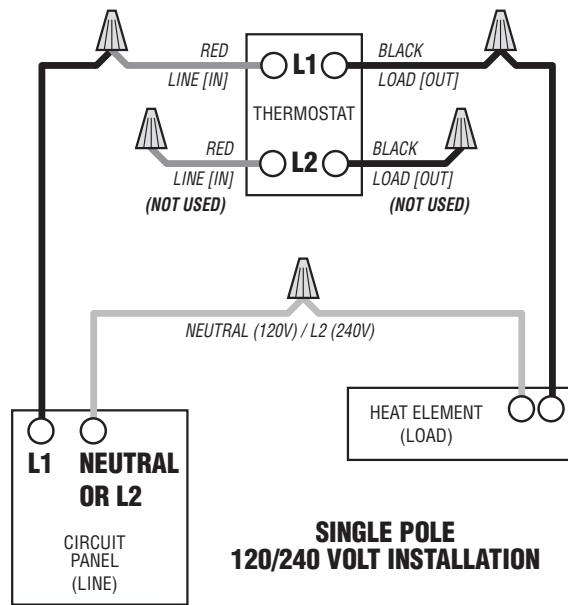
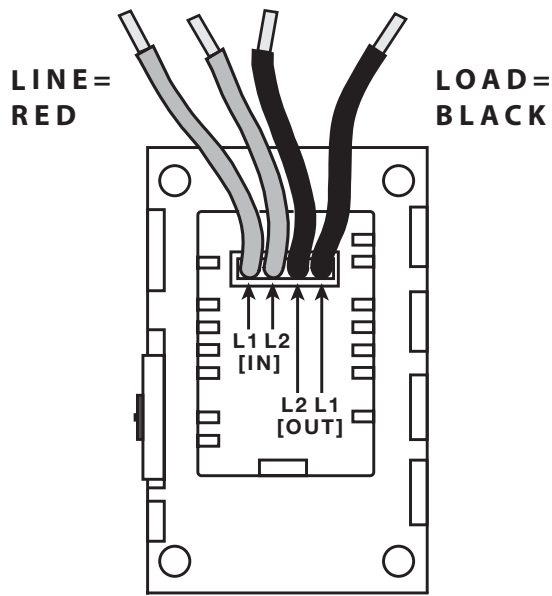

WIRING DIAGRAM NOTES:

1. This Double Pole thermostat model may be used in either Single Pole, or Double Pole wiring configurations. Only the LINE 1 (IN) and LOAD 1 (OUT) terminals are switched during normal temperature cycling. If this thermostat is used in a Single Pole configuration, the unused L2 LINE (IN) and L2 LOAD (OUT) wire ends must be securely insulated using the additional wire connectors provided.
2. To avoid the risk of fire hazard, all connections made to aluminum conductors must be made using approved CO/ALR solder-less wire connectors. DO NOT use the supplied wire connectors if you are making connections to aluminum wiring.

(ELV4) FRANÇAIS – SCHÉMAS D'IDENTIFICATION DES FILS ET DU CÂBLAGE

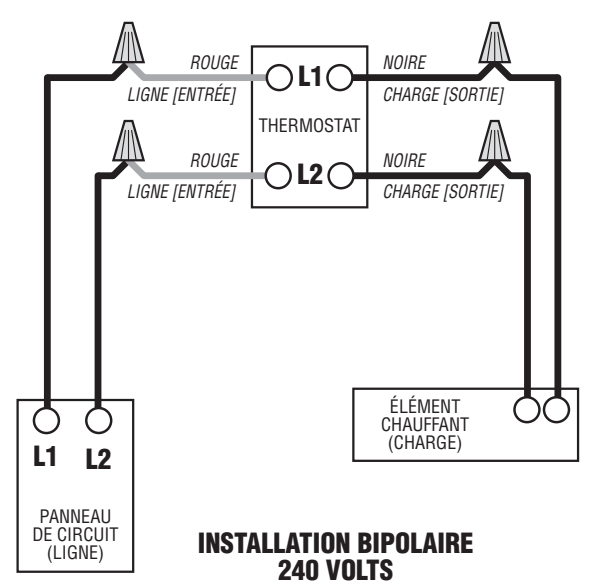
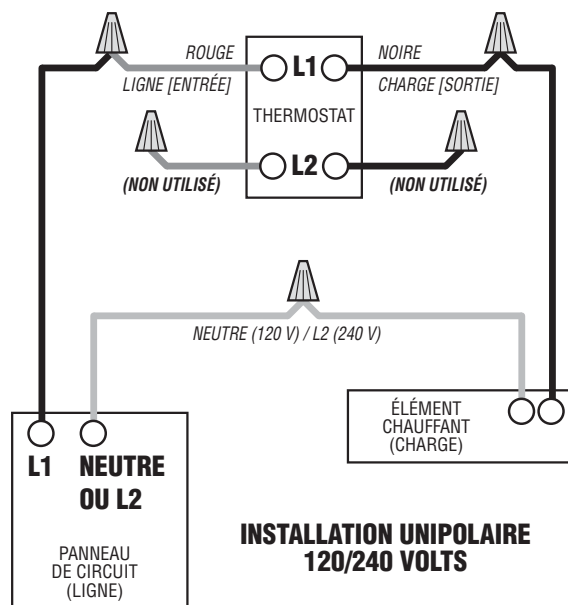
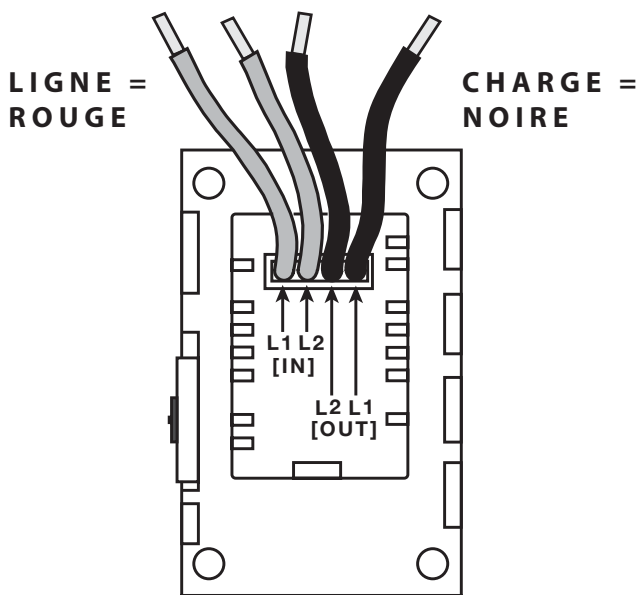

NOTES DU DIAGRAMME DE CÂBLAGE :

1. Ce modèle de thermostat bipolaire peut être utilisé dans des configurations de câbles unipolaires ou bipolaires. Seules les bornes de la LIGNE 1 (ENTRÉE) et de la CHARGE 1 (SORTIE) sont branchées lors d'un cycle de température normal. Si ce thermostat est utilisé dans une configuration unipolaire, les extrémités de fils L2 LIGNE (ENTRÉE) et L2 CHARGE (SORTIE) inutilisées doivent être bien isolées en utilisant les raccords supplémentaires fournis.
2. Pour éviter les risques d'incendie, tous les raccords aux conducteurs en aluminium doivent utiliser des raccords sans soudure approuvés CO/ALR. N'utilisez PAS les raccords fournis pour des raccords au câblage d'aluminium.

(ELV4) ESPAÑOL – IDENTIFICACION DE CABLES Y DIAGRAMAS DE CABLEADO

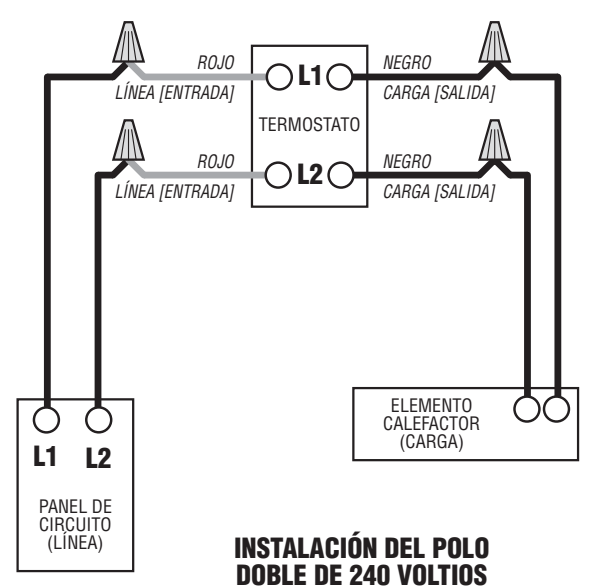
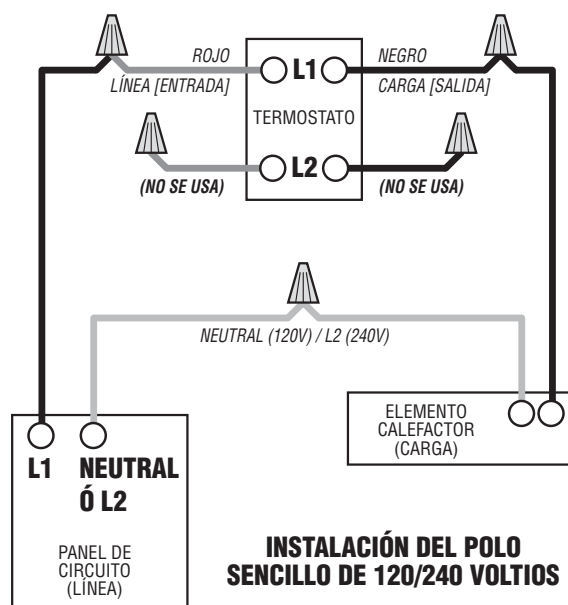
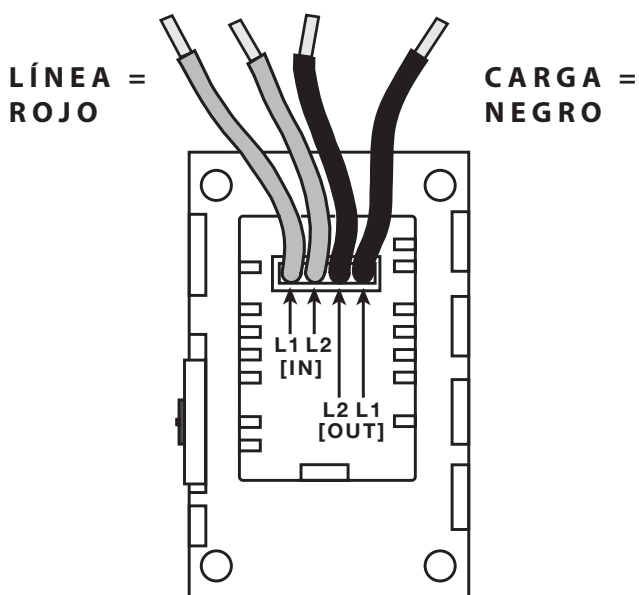

NOTAS DEL DIAGRAMA DEL CABLEADO:

1. Este modelo de termostato de doble polo puede usarse con configuraciones de cableado con polo sencillo o doble. Sólo las terminales LÍNEA 1 (ENTRADA) y CARGA 1 (SALIDA) se conectan en el ciclo normal de temperatura. Si este termostato se usa con una configuración de cableado con polo sencillo, los extremos de los cables de la LÍNEA L2 (ENTRADA) y CARGA L2 (SALIDA) que no se utilicen deben aislarse adecuadamente con la ayuda de los conectores de cable adicionales que vienen incluidos.
2. Para evitar el riesgo de incendio, todas las conexiones a conductores de aluminio deben hacerse usando conectores de cable sin soldadura que tengan la aprobación CO/ALR. NO utilice los conectores de cable que vienen incluidos si realiza conexiones a cableado de aluminio.